



TYLÖ AB, Svarvaregatan 6, S-30250 Halmstad, Sweden.
Tel + 46-35 10 00 80, Fax + 46-35 102580.
Email: info@tylo.se, Internet: www.tylo.se



Installation and operating instructions with checklist for faults

Read through these instructions carefully before installation, and follow them in every respect to ensure flawless operation every time. After installation, please give these instructions to the owner or the person who will operate the steam room.

PLEASE KEEP THESE INSTRUCTIONS IN A SAFE PLACE - THEY CONTAIN IMPORTANT INFORMATION ABOUT SERVICE AND MAINTENANCE PROCEDURES.

IMPORTANT!

- Do not make sharp bends or "elbows" along the steam pipe.
- Do not direct the steam jet at a wall, seating or any other object. There should be a free space of at least 70 cm (28") in front of the steam nozzle.
- Do not allow sags or "water pockets" along the steam pipe and/or the ventilation duct. **IMPORTANT!** There must not be any type of obstruction along the steam line, such as a stop-off valve or tap. The internal diameter of the steam pipe must not be reduced.
- Ensure that steam rooms that are used continuously for more than two hours at a time are ventilated by 10–20 cubic metres of air per person and hour.
- The power supply to the steam generator via the feeder cable must not be broken. For that reason, avoid switches, etc., along the feeder cable.
- Make sure that the drainage pipe slopes all the way down to the waste outlet.
- The ambient temperature outside the steam room and around the steam generator must not exceed 35°C.
- Place the thermostat sensor as far away from the steam jet as possible.
- De-scale the steam generator at regular intervals as instructed. (Please read the section 'De-scaling' for further details). In hard-water areas, where calcium levels exceed 5°dH, we recommend the installation of a water softener or a Tylö automatic de-calcifier.
- Clean the steam room regularly. See the section on "Cleaning the steam room" under Operating instructions.
- IMPORTANT.** The steam generator's wastepipe must always discharge into a drain outside the steam room itself. The water is very hot.

General Information.

Fig. 1.

Examples of ventilation, electrical and plumbing installation.

X = feeder cable from mains to steam generator. Do not fit a switch along this cable. Where local regulations require a switch to be fitted, this switch must always be in the ON position. If the electrical supply is interrupted before the automatic emptying and flushing functions have occurred (approx. 80 min after completion of bathing) these functions are terminated without the reservoir being emptied. This reduces the life expectancy of the steam generator.

Y = control cable from mains supply via control panel to steam generator.

V = thermistor cable.

Z = cable to external on/off switch (if any).

D = steam pipe.

E = drainage pipe.

F = incoming water.

G = air inlet.

H = air outlet, leading out via a ventilation duct into the open air.

The steam room.

The steam room should not have any other source of heat than the steam generator. The ambient temperature around the steamroom and the steamgenerator generator should not exceed 35°C (95°F). If there is a sauna next to the steam room, the sauna must be well insulated, and placed so as to give at least 10 cm (4") free space between the outside walls of the sauna and the steam room.

Location of the steam generator.

The steam generator must be installed by an authorised electrician/plumber. The steam generator must be permanently installed and secured against existing floor or wall. It is to be located outside the steam room itself, but as close to it as possible – no more than 15 m (50 ft) away.

The steam generator must be placed in a dry and ventilated space with a waste outlet, above, below or on the same floor as the steam room, and concealed in a cupboard, wardrobe, etc. (Never directly above a waste outlet or in an aggressive environment).

The steam generator must be mounted horizontally, at a suitable height above the floor to permit the drainage pipe to slope towards the waste outlet. To achieve this, it may sometimes be necessary to place the steam generator on wall brackets, or a floorstand.

CC control panels.

Instructions: included with the control panel.

To be installed outside the steamroom, at any distance from the steam room.

CC panels are electronically operated and are available in the following models:

CC 10-3. Manual and automatic on/off. Maximum 3- hour running time, 10 hour pre-set.

CC 50. Manual and automatic on/off. Maximum 3 or 12 hour running time, 10 hour pre-set.

CC 100. Manual and automatic on/off. Maximum 3 or 12 hour running time, 24 hour pre-set. Built-in weekly timer

Thermometer.

The thermometer in the steam room should be placed at a height so that the temperature corresponds exactly to the numbers in the names CC 50/ CC 100.

Temperature limit control.

Tylö steam generators are equipped with a built-in temperature limit control. If the control is triggered off, consult the checking and fault-finding list in this manual to find the causes and a solution to the problem.

Note! The High temp limit control in a VA generator must be reset by a Qualified electrician.

Main power switch.

On the bottom of the smaller steam generators is a power switch, which should only be used if the unit is to be disconnected for a long time.

The automatic emptying function ceases any time the power is cut off.

Floors and drainage.

There must be a drain in the steam room, and the steam room floor must slope towards the drain. The floor may be covered with seamless vinyl flooring, quarry tiles, etc. The requirements for sub-floor work, joining, etc., are the same as for an ordinary shower.

PLEASE NOTE. Contact with steam and hot water may cause plastic wallcovering/flooring close to the steam head to become slightly discoloured.

Ventilation.

As a general rule, steam rooms which are in use for less than two hours at a time require no special ventilation. In order to ensure proper hygiene and trouble-free operation, steam rooms which are in continuous use for more than two hours at a time should be ventilated with 10–20 cubic metres of air per person and hour.

If there is a gap above the steam room, do not seal it. To ventilate a cavity above the sauna, drill or cut at least one ventilation hole (1000mm²) into the cavity through the wall on which the sauna door is located.

The **air inlet** may be an opening placed low down on the same wall as the door, or it may be a gap under the door.

The **air outlet** should be located high up on a wall or in the ceiling, and as far away from the air inlet as possible.

However, the air outlet must not be located above the door or directly above any of the seats. Connect the outlet to a ventilation duct discharging into the open air. Use existing ducting, if possible. The ventilation ducting must be 100% steamtight and watertight, and made of materials which will not deteriorate or corrode in the high humidity. Do not allow the formation of "water pockets", caused by sags in the ducting, where condensed steam may collect as water and cause a blockage. If a water pocket is inevitable, install a trap to drain the condensed water into the waste outlet.

The air outlet vent must be of sufficient size to allow the evacuation of 10–20 cubic metres of air per person and hour.

Mechanical ventilation. If the unassisted through-flow of air is insufficient, due possibly to negative pressure in the room supplying air to the steam room, a mechanical exhaust fan must be installed and adjusted to extract a minimum of 10 and a maximum of 20 cubic metres of air per person and hour.

Steam generator functions.

All TyLö Model VA/VB Steam Generators incorporate these features:

- Stainless steel water reservoir
- Tubular heating elements, resistant to rust and acid
- Automatic emptying 1 hour after the steam bath has been switched off
- Automatic flush function rinses 4 times after emptying
- 3-part output
- Electronic water-level regulator
- Electronic water level control
- Self-cleaning, calcium-repellent electrodes
- Continuous steam production
- Always the right output, regardless of quantity and quality of water
- Built-in safety valve
- Built-in temperature cut-off
- Built-in filter
- Equipped for remote-control operation
- Adjustable steam head
- Splashproof finish.

Automatic emptying.

This automatic function considerably reduces the build-up of calcium carbonate and other deposits in the water reservoir. Do not switch off any switches between the mains supply and the steam generator until at least 80 minutes after the control panel timer has turned the system off, because otherwise, the automatic emptying and flushing of the water reservoir will not start.

WARNING. The water is very hot.

Automatic flushing with DIP switch.

The steam generator is factory set to flush out part of the water automatically after 4 hours. The steam generator should, however, be emptied more frequently in areas where the water is hard (5dH° or more than 100 ppm calcium carbonate), or if it is used for more than four hours per day. Set the required interval using the DIP switches as shown (fig. 17).

WARNING. The water is very hot.

De-scaling.

Some of the limescale released from the water in the steam generator is flushed out in the automatic emptying and cleaning process; some, however, remains. The TyLö Automatic De-calcifier (art no. 9090 7000) does not remove limescale deposits as such, but modifies the ions in such a way that more of the calcium is evacuated during the flushing process. For this reason it is essential to check that the automatic emptying function of the steam generator has not been impaired by incorrect wiring. The reservoir must be emptied each time it has been used.

To maximise serviceable life and reduce the need for the manual removal of limescale deposits, we recommend that steam generators for use in public facilities should be connected to a water softener which removes calcium from the water. This is particularly important if the hardness of the water is greater than 5 degrees German. (5 °dH, see table.)

The water softener must not generate any froth on the water nor produce any harmful chemical reactions. If so, the generator may indicate the wrong water level and trigger the temperature cut-off. (Repeated activation may result in the failure of the elements.)

The manual removal of limescale must be carried out at regular intervals as specified in the table below.

For normal private use, there is little need for the manual removal of limescale, unless the water is very hard. Even so, it is advisable to de-scale the steam generator at least once per year. This removes calcium and other deposits that have become encrusted on the walls and elements of the water reservoir.

Instructions for de-scaling TyLö Steam Generator

- Switch on the steam generator and let it run until the water in the tank begins to boil.
- Switch the generator off and wait for approximately 5 minutes.
- Unscrew the capping nut from the 3-way connector on top of the steam generator.
- Use a funnel to pour the de-scaling agent into the tank via the 3-way connector.
- Screw the capping nut back in place on the 3-way connector and leave the de-scaling agent to work.
- After approximately 1 hour the generator will automatically empty and flush the tank. After this the steam generator is once more ready for use.

Tylö Solvent is harmless, odourless, will not damage the components in the steam generator and allows you to use the steam generating function during the de-scaling process. If you use any other type of de-scaling agent, do not use the steam bath until after the de-scaling operation has taken place.

As the table shows, how often manual de-scaling needs to be done depends on the quality of the water, the output of the steam generator and the total operating time.

Operating time before de-scaling					
(To reduce the need for manual removal of limescale we recommend the use of softened water in public facilities)					
Steam generator output kW	Amount of de-scaling agent (1 pack 80g)	Operating time for different water hardnesses			
		Softened 0,01-1°dH	Soft 1-3°dH	Hard 3-8°dH	Very hard 8-20°dH
2,0-2,5	2 pack	7000	2300	900	350
3,8-5	2 pack	3800	1300	500	190
5,6-7,5	2 pack	2600	900	300	130
7,5-9	2 pack	1700	600	200	90
10-13	2 pack	1300	400	160	70

(1-dH = 7.14 mg calcium / litre water)

How to make the most of a steam bath.

Most people find that the most comfortable steam bathing temperature is between 40 and 45°C. Use a bi-metallic type of thermometer to check the temperature. Fix it on the wall about 170 cm (67") above floor level, as far from the steam jet as possible. There is no need for a hygrometer. The relativity is always 100%.

- Shower and wash before starting your steam bath.
 - Take a towel to sit on in the steam room.
 - Relax and enjoy the soothing clouds of steam. You can even listen to your favourite music while you do so. A stereo unit with speakers specially made for steam bath listening is available from Tylö's range of accessories.
 - Cool down now and again with a refreshing shower. Alternate between the steam bath and the shower for as long as you feel it is comfortable.
 - After your last spell amongst the clouds of steam, you'll find a long, cool shower a real delight.
- Let your body dry off naturally before putting your clothes on. Relax, treat yourself to a cold drink and enjoy a sensation of true well-being. Don't get dressed until your body has cooled down and your pores have closed once again.

Cleaning the steam room.

Rinse seats and flooring with warm water (do not use a high-pressure hose) each time the steam room has been used. Wash the seats regularly with a mild soapy solution. For daily disinfection, we recommend the Tylö Steam Clean unit, which is fully automatic. Stubborn stains can be removed with ethanol or petroleum (mineral) spirits. Never use scouring powder, strong alkaline cleaners or aggressive solvents on the seats and walls in the steam room. Contact your Tylö representative if you are unsure of how to remove stains. It is important that the steam room floor is cleaned thoroughly – right into the corners. Scrub clean with hot water and a floor cleaner, which will remove grease and grime.

Shower in the steam room.

We always recommend installing a shower in domestic steam rooms. After all, a steam room also makes the best shower room imaginable. And it is so pleasant to cool off with an invigorating shower now and again during a steam bath.

Fig. 2.

Measurements in millimetres: Tylö Model VA Steam Generator.

Fig. 3.

Measurements in millimetres: Tylö Model VB Steam Generator.

Required output in relation to cabin size:

kW	Min/Max volume of the steam room in cubic metres				Steam prod. kg/h
	Lightweight walls (tempered glass, Elysée/Excellent rooms, etc.)		Heavy walls (tiles, concrete, stone, etc.)		
	with ventilation	without ventilation	with ventilation	without ventilation	
2.5	-	0-2.5	-	0-1.5	3
3.8-4.5	0-4	0-5.5	0-2.5	0-3.5	5.5
5.6-6.0	3-8	4-15	2-5	2.5-8	8
6.6-7.5	3-9	4-17	2-6	2.5-9	9
9-9.9	6-16	13-24	4-10	7-16	12
10-13.2	14-22	22-30	8-15	14-20	16

Plumbing installation

To be carried out only by a qualified plumber.

Steam generator kW	No. of steam outlets	No. of safety valves	No. of drainage connections	No. of water connections
2,2-13,2	1	1	1	1

Fig. 4.

Steam generator Model VA.
A = pipe joint.
B = capping nut.
C = steam outlet.
D = drainage connection. (safety valve)
E = water connection with integral filter.
F = cover for the electrodes.

Fig. 5.

Steam generator Model VB.
A = pipe joint.
B = capping nut.
C = steam outlet.
D = drainage connection. (safety valve)
E = water connection with integral filter.
Water connection: connect hot or cold water to pipe joint 1 on the steam generator. Hot water allows faster heating. A flexible reinforced rubber hose (approx. 1 metre [3'3"] long) is used to connect the copper piping (internal Ø at least 12 mm [½"]) and the steam generator to prevent noises in the system.
IMPORTANT! Flush the pipes thoroughly before connecting the incoming water supply to the steam generator.
 Flushing the pipes prevents any metal filings or other foreign bodies from getting into the steam generator's system.

Note:

In hard-water areas, where calcium levels exceed 5°dH, we recommend the installation of a Tylö automatic de-calcifier or a water softener to remove calcium from the water. (Tylö accessory: Automatic Decalcifier art. no. 9090 7000). The water softener must not generate any froth on the surface of the water or produce harmful chemicals.

This is especially advisable for public installations.

Steam pipe: Connect the pipe joint to the steam outlet (2) on the generator, with the capping nut upwards. Connect a length of copper piping (internal diameter at least 12 mm [½"]) to the steam outlet on the pipe joint. (C). The steam pipe must slope down towards the steam room and/or the steam generator – or towards both.

Fig. 6.

IMPORTANT! There must be no "water pockets" or sags where steam may condense and collect as water along the piping between the steam generator and the steam room.

Fig. 7.

Plan for as few bends as possible in the steam pipe. Such bends are to be gently curved, with a minimum radius of 5 cm (2"). Avoid any sharp "elbows" in the pipes.
IMPORTANT! There must not be any type of obstruction along the steam line, such as a stop-off valve or tap. The internal diameter of the steam pipe must not be reduced. If the steam pipe is more than 3 metres (9'9") long, it should be insulated along its full length. The distance between any combustible material (e.g. wood) and an uninsulated steam pipe must not be less than 10 mm (0.4").

Figs. 8 and 9.

Fitting the steam head.

A = adjustable steam spout (use as required).

IMPORTANT

The steam head is to be fitted inside the steam room between 5 and 40 cm (2-16") above floor level. In principle, steam is released into the room lengthwise under the seating. Do not direct the steam jet at walls, seating or any other object. There should be at least 70 cm (28") free space in front of the steam head. In steam rooms where there is no space under the seats, the jet of steam should be directed diagonally upwards. Set the spout so that the jet of steam is directed away from the bathers. If the steam room is used by children or people whose quick reactions are impaired, etc., a guard should be fitted to prevent inadvertent contact with the jet of steam issuing from the steam head. Consult the assembly instructions accompanying the steam room if the steam head is to be fitted in Tylö's steam room.

Drainage

Drainage from the steam generator. Fit the drainage pipe (copper piping with minimum 12 mm internal diameter) to connection number 3 on the steam generator. The pipe must lead directly to the nearest drain outside the steam room itself. The temperature of the water that is drained off is approximately 95°C/200°F.

IMPORTANT! There must be no blockage of any type (tap, faucet, etc.) along the drainage pipe.

Regardless of where the drainage head is located, it must slope all the way from the steam generator to the waste outlet. Under certain conditions, it may be necessary to place the steam generator on wall brackets or a stand to achieve the right angle.

Electrical installation.

To be carried out only by a qualified electrician.

The power feed to the steam generator is taken directly from the mains fuse box. There must be no switches, etc. along this feed line. See also under "Automatic emptying".

Wiring diagrams 10 - 15 show wiring to one VA or VB generator. Two steam generators can be linked to the same steam room and controlled by a control panel; see fig. 16.

Don't forget to earth the unit!

Fig. 1 – steam bath.

- 1 = steam generator.
- 2 = thermistor (sensor).
- 3 = control panel CC 10/ CC 50/ CC 100.
- 4 = external on/off-switch (if any).
- 5 = mains fuse box.

Lighting.

Can be regulated by a control panel. Maximum lighting voltage: 24 volts. Carefully seal all holes made for wiring. Connect the lighting according to the wiring diagram.

Placement of the thermistor (sensor).

Place the sensor 150-170 cm above floor level inside the steam room.

Important: Place the sensor as far from the steam jet as possible. It must not be hit by the jet directly or indirectly. The thermistor wire can be extended outside of the steam room with a shielded low-voltage cable (2-core).

Shielded low-voltage cable (LiYCY, 6-core).

The control cable between the CC 10/ CC 50/ CC 100 and steam generator must be a shielded low-voltage cable (LiYCY, 6-core). Connect the shielded cable to plinth 12 in the control panel.

Option: external on/off-switch (momentary).

Can be placed at any distance from the steam bath. Connected with a low-voltage cable to the CC 10/ CC 50/ CC 100 – see the wiring diagram. If there are several external on/off switches, they should be parallel-connected.

Connection to a central computer.

The control panel can also be connected to a central computer, which gives a brief impulse (closure) between plinths 19 and 20 in the CC 10/ CC 50/ CC 100

Connecting any extra equipment

The P5 and G6 connections are intended for connection of mechanical ventilation, the Steam Fresh scent unit, the Steam Clean disinfection unit, etc.

WARNING! SEVERAL SUPPLY CIRCUITS. CHECK THAT THERE IS NO CHARGE IN THE MACHINE BEFORE DOING ANY MAINTENANCE WORK!

Checking and fault-finding.

In the event of faulty operation, first check the following:

- are the control panel and steam generator wired up in accordance with the wiring diagram?
- is the steam generator correctly installed in accordance with these instructions?
- does the drainage pipe slope down properly towards the waste outlet?
- is the filter clogged? The filter is located at the point where incoming water is fed into the generator. To clean the filter, disconnect the feed pipe, remove the filter and rinse it free from particles of calcium carbonate and other deposits.
- are there any sags along the steam pipe or along the ventilation duct leading from the steam room?
- are there any sharp bends in the steam pipe? (the minimum permitted radius of bends is 50 mm, 2")
- if there is a tap on the water supply to the steam generator, make sure this is not closed.
- does the construction and ventilation of the steam room comply with Tylo's instructions?

Checklist

with alternative causes of problems and suggested actions.

The steam room maintains the desired temperature (40–50°C, 105–122°F), but no steam is produced.

Cause: Insufficient ventilation in the steam room.

Solution: Increase ventilation. The ventilation is insufficient if less than 10–20 cubic metres (13–28 cub. yd) of air per person per hour is evacuated via the outlet vent. This situation may occur if the outlet vent is not connected to some form of mechanical extractor fan – or if the ventilation duct is blocked by a water pocket.

Cause: The air coming into the steam room is too warm.

Solution: Reduce the intake air temperature to 35°C (95°F).

Cause: The ambient temperature is higher than 35°C (95°F).

Solution: Ensure that the ambient temperature does not exceed 35°C (95°F).

Cause: The thermometer is faulty or wrongly placed.

Solution: The thermometer should be placed approximately 170 cm (67") above floor level and as far away from the steam jet as possible.

The steam room requires an abnormally long time to heat up.

Cause: The generator is not powerful enough. See table.
Solution: Replace the steam generator with one with a higher heat output.

Cause: Excessive ventilation in the steam room.

Solution: Reduce the ventilation to evacuate 10–20 cubic metres (13–26 cub. yd) of air per person per hour.

Cause: Blown fuse in the mains fuse box.

Solution: Replace the fuse.

Cause: The ambient temperature is lower than 15°C (59°F).

Solution: Increase the ambient temperature or replace the steam generator with a more powerful one.

Cause: Heating element is broken.

Solution: Replace reservoir.

Cause: The thermostat sensor is too close to the steam jet. See test 2.

Solution: Move the sensor or change the direction of the steam jet.

Neither steam nor heat is generated in the steam room.

Cause: Blown fuse in the mains fuse box.

Solution: Replace the fuse.

Cause: The water is not reaching the steam generator.

Solution: Open the tap(s) connected to the piping to allow incoming water to flow into the steam generator.

Cause: The control panel is incorrectly set.

Solution: Check the time and temperature on the control panel.

Cause: The filter is clogged.

Solution: Remove the filter which is placed in the connection for incoming water. Clean off any metal filings or other foreign bodies.

Cause: The solenoid valve for water supply has stuck.
Solution: Remove the solenoid valve and clean off any metal filings or other foreign bodies.

Cause: Excessive calcium carbonate deposits in the steam generator's water reservoir. See test 1.

Solution: Replace the entire water reservoir, including heating elements and electrodes.

Cause: The steam generator is wired up for the wrong voltage.

Solution: Check the voltage and the connection to the generator – see diagram.

Cause: The temperature limit control has been triggered, see test 4.

Solution: Check and remedy any faults on the steam pipe, such as a blockage due to several sharp bends, water pockets or greatly reduced internal diameter. The tank may also be clogged with limescale; see above.

Cause: Flaw in the circuit board, control panel or magnetic operated vent.

Solution: Replace the faulty component.

Hot water runs from the steam head. Little or no steam in the steam room.

Cause: The solenoid valve for incoming water has stuck, due to accumulated deposits of foreign bodies or an electrical malfunction. See test 3.

Solution: Remove the valve and clean it, or rectify the electrical malfunction.

Cause: The solenoid valve is broken.

Solution: Replace the valve.

Cause: Malfunction in the circuit board.

Solution: Replace the circuit board.

Hot water comes out of the steam head in spurts or in a slight, even flow mixed with steam.

Cause: Small water pocket along the steam pipe.

Solution: Eliminate the water pocket.

Cause: The steam pipe is uninsulated along too great a portion of its length.

Solution: Insulate the steam pipe.

A continuous trickle of hot water from the steam generator's drainage pipe.

Cause: The solenoid valve for automatic emptying has stuck.

Solution: Switch off the steam generator. See what happens again after an 80-minute pause. If the fault persists, remove the solenoid valve for the automatic emptying function and clean it.

Loud noises in the feed pipes when the solenoid valve opens or closes.

Cause: The steam generator feed pipes are not sufficiently secure.

Solution: Fix the pipes securely to the wall with pipe clips.

Cause: "Recoil" problems in the feed pipe (Pipe hammer).

Solution: Replace a metre-long length of piping nearest the steam generator with flexible piping, for example, reinforced rubber hosing, which will withstand the pressure.

Safety valve opens or temperature cut-off is activated.

Cause: The steam pipe is blocked; see test 4.

Solution: Remove the blockage.

Cause: The internal diameter of the steam pipe is considerably reduced. See test 4.

Solution: Replace the pipe or the pipe joint which is causing the reduction (Internal diameter must be at least 12 mm, ½").

Cause: Sharp bends ("elbows") along the steam pipe. See test 4.

Solution: Get rid of "elbows" in the pipe. Bends are to be gently rounded (minimum radius 50 mm, 2").

Cause: Large water pocket somewhere along the steam pipe. See test 4.

Solution: Adjust the steam pipe to eliminate the water pocket.

Cause: Excessive calcium carbonate deposits in the steam generator's reservoir. See test 1.

Solution: Replace the entire reservoir, including elements and electrodes.

Erratic steam production right from the start.

Cause: The thermostat sensor is wrongly placed in relation to the steam jet. See test 2.

Solution: Move the sensor or alter the direction of the steam jet.

Cause: Calcium carbonate or other foreign bodies in the filter.

Solution: Remove and clean the filter.

TEST 1.

Test for calcium deposits in the reservoir.

Unscrew the capping nut at the top of the steam generator. Lower a torch bulb, wired up to a battery, into the hole. Inspect the illuminated tank through the hole. If there is a layer of calcium carbonate extending more than three centimetres above the bottom of the tank, the reservoir has not been serviced as prescribed with regular applications of a de-scaling agent.

The problem may also be that the emptying and flushing systems are no longer operative. If there is a switch along the feed cable to the steam generator, check that this has not been used as an OFF switch after steam bathing. A switch in the feed cable must not be switched off until at least 80 minutes after the control panel has turned off the system.

Make sure that the automatic emptying function is working, by placing a suitable vessel (capacity approx. 3 litres, 5 pints) under the drainage valve. Switch on the steam generator and let it remain on for 15 minutes.

Switch off the generator in **exactly** the same way as you always do when turning off the steam bath for the day.

Wait at least 80 minutes, and then check that the vessel is full of water. If this is not the case, either the steam generator has been incorrectly wired up, or the power to the generator has been interrupted in some other way along the cable from the electric supply to the generator, or alternatively there is a fault in the drainage valve or the circuit board.

TEST 2.

Temperature sensor test.

Soak a small towel in cold water. Hang the wet towel over the thermostat sensor. If, within 20 minutes, the steam generator has started to produce steam continuously, the equipment is not defective, but the thermostat sensor (bulb) is located in an unsuitable position, or the thermostat itself is set for too low a temperature. If steam production does not begin, use the checklist to find out the cause.

TEST 3.

Solenoid valve check.

Use the control panel to switch off the steam generator. If water continues to trickle out of the steam head more than 10 minutes after the control panel has been switched off, the cause is dirt in the solenoid valve. Remove and clean the valve.

If the water stops running through the steam head within 10 minutes after the control panel has been switched off, the cause is an electric fault (incorrect connection or circuit board fault). Or, alternatively, excessive calcium carbonate has accumulated in the reservoir. See test 1.

TEST 4.

Steam pipe test if the safety valve or the temperature cut-off is activated.

Disconnect the steam pipe from the steam generator. Start the generator and let it remain on for about 1 hour. If the safety valve or the temperature cut-off is not activated during this test, there is a blockage along the steam pipe which is preventing the passage of steam. Take the necessary steps according to the information in the checklist.

If, during service, you wish to empty the tank, disconnect the spade connector on the emptying valve and connect the 230 volts' mains supply directly to the solenoid valve.
IMPORTANT: This operation may only be carried out by an authorised electrician.

TYLÖ

TYLÖ AB, Svarvaregatan 6, S-30250 Halmstad, Sweden.
Phone 035-10 00 80, Fax 035-102580.
Email: info@tylo.se, Internet: www.tylo.se

© This publication may not be reproduced, in part or in whole, without the written permission of Tylo. Tylo reserves the right to make changes in materials, construction and design.

So that the steam generator's automatic emptying and rinsing functions are not rendered inoperative (which may reduce the life of the generator), it is essential that there is always a current in the power feed cable X. An exception may, of course, be made when servicing the steam generator. The steam generator is always switched on and off from the control panel or some other switch, timeclock etc. which is connected to the cable marked Z.

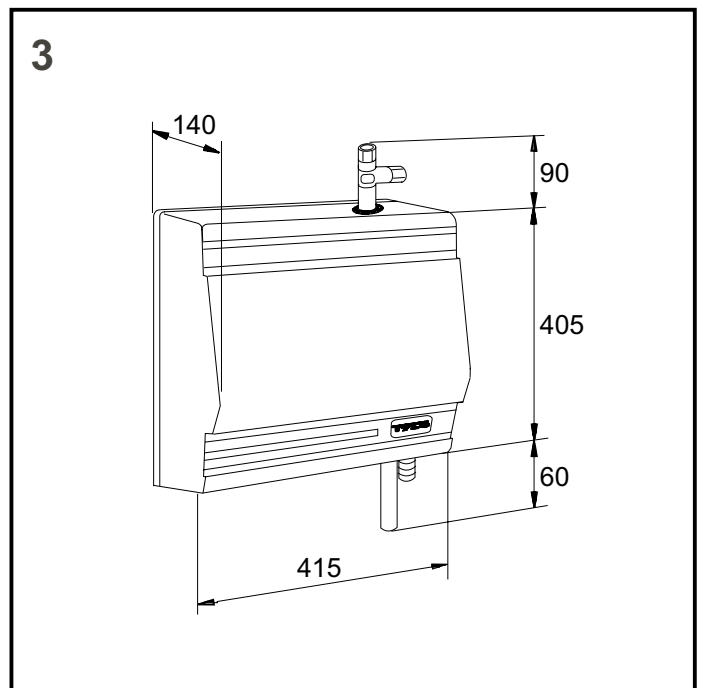
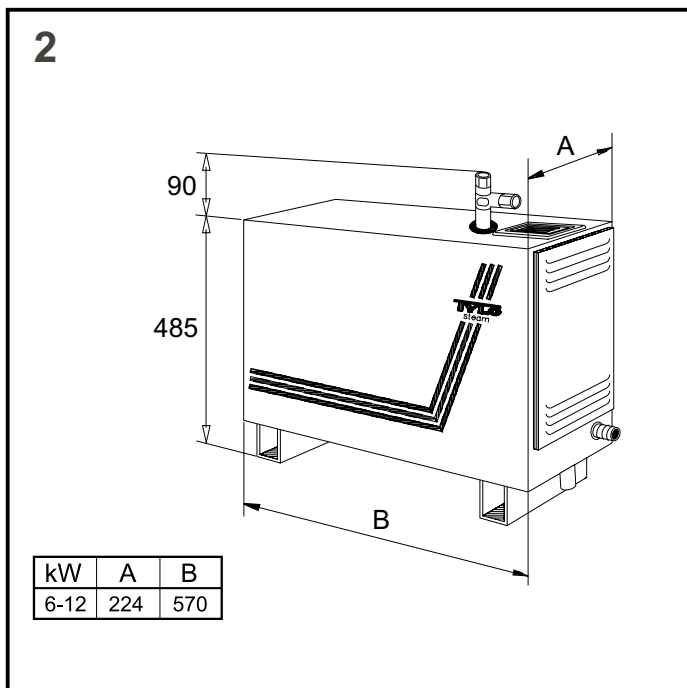
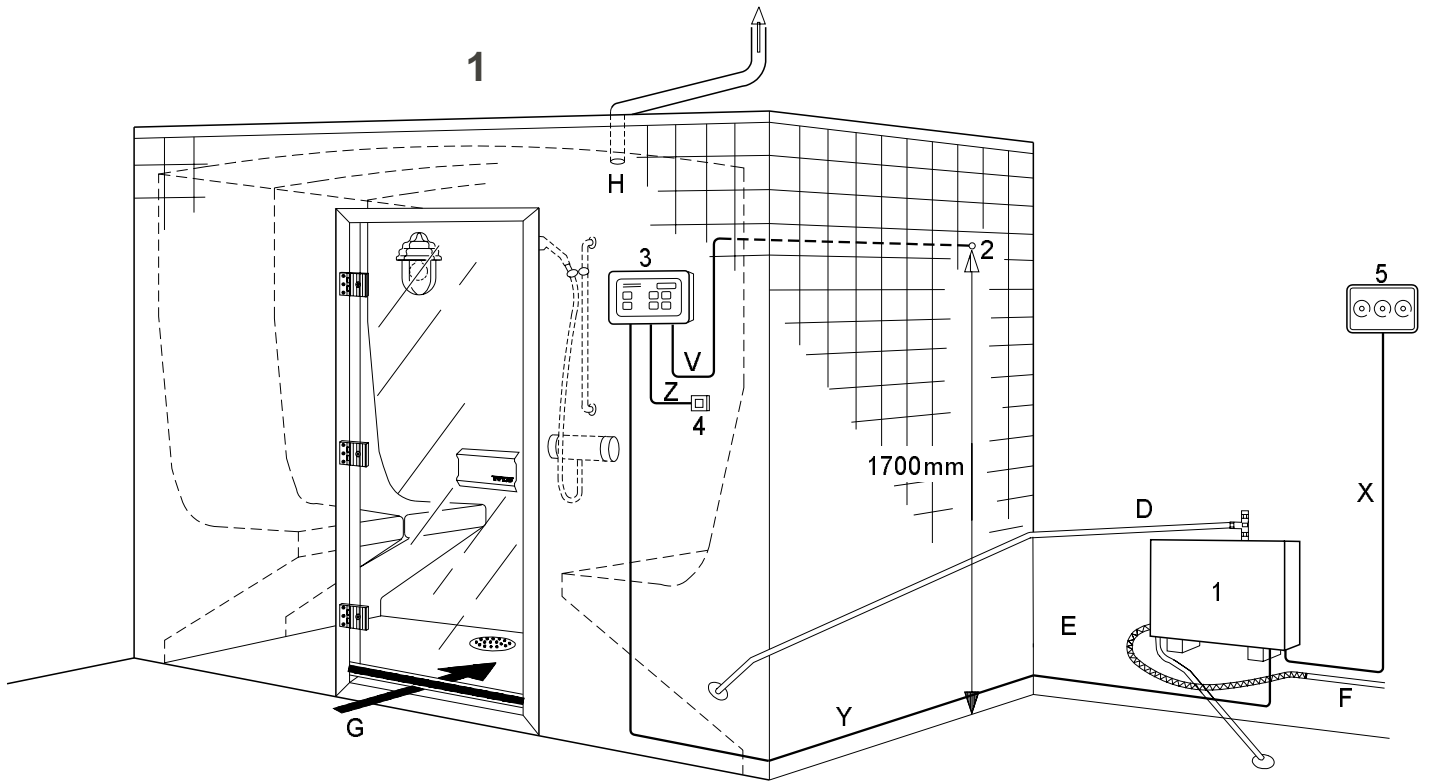

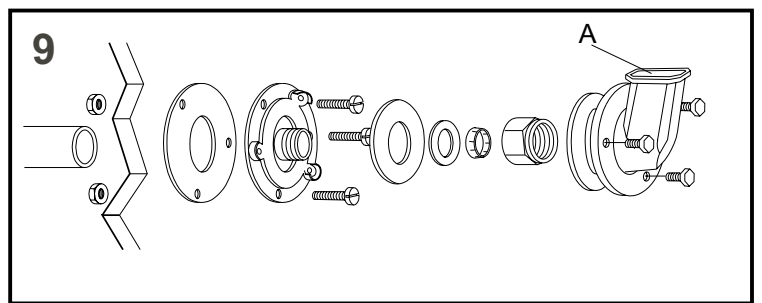
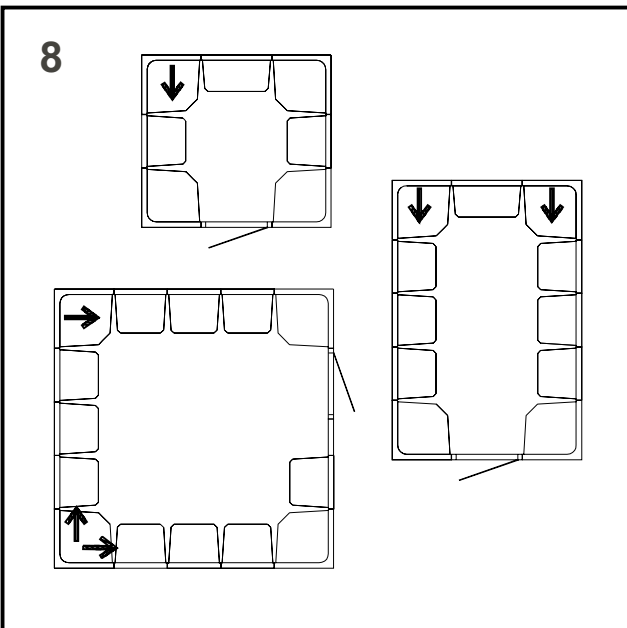
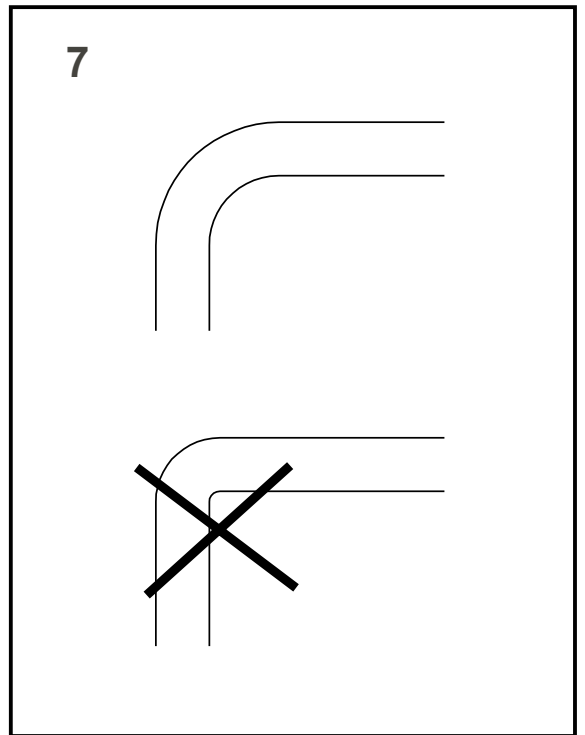
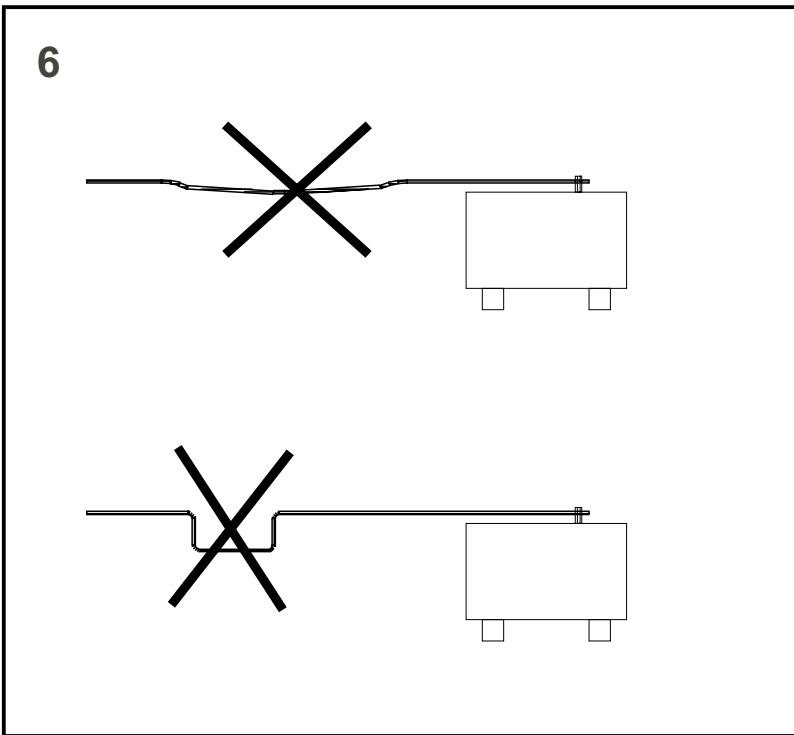
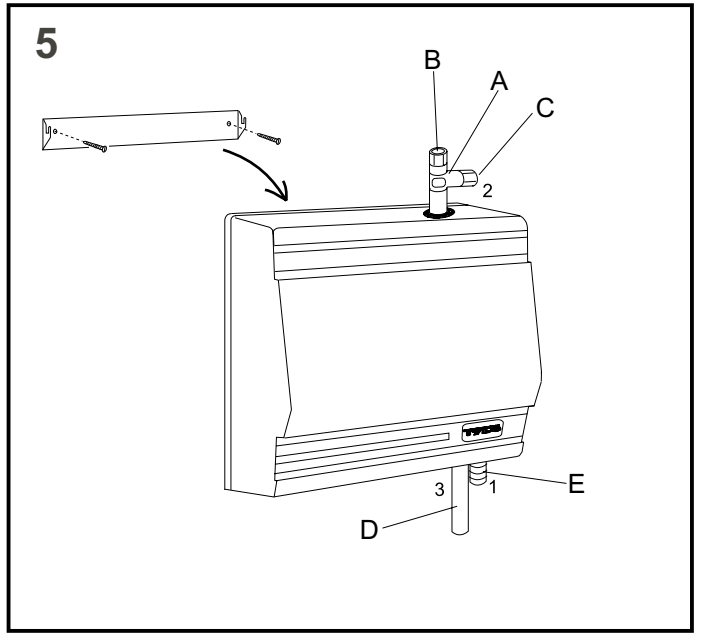
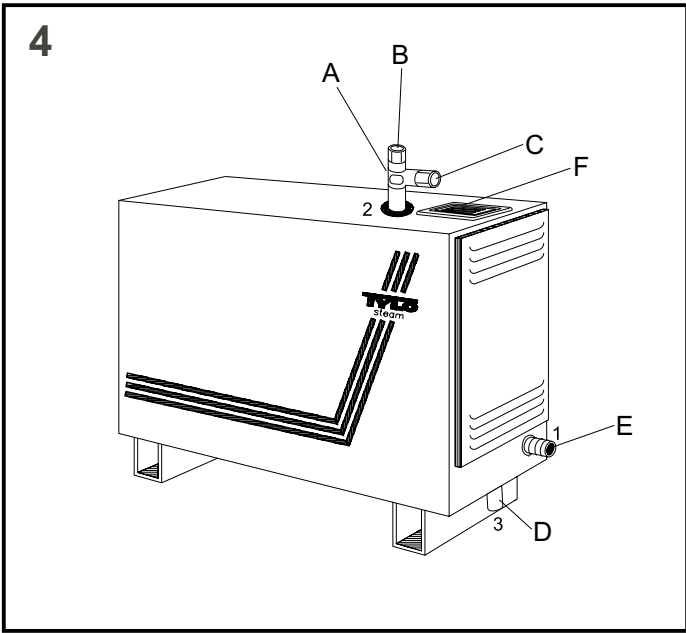

10

STEAM: Type VA, 5 - 13,2 kW, Type VB 6 (5,6 / 7,5 kW) 208 / 240 V 3~

TAB

kW	208 V 3~		240 V 3~	
	Amp	AWG	Amp	AWG
5	14	12	-	-
5.6	16	12	-	-
6	18	10**	-	-
6.6	-	-	16	12
7.5	21	10*	18	12
9	26	10**	-	-
9.9	-	-	24	10**
10	28	8**	-	-
12	35	6**	-	-
13.2	-	-	32	8**

- 1 = VA, VB
- 2 = thermistor (sensor)
- 3 = CC10, CC50, CC100
- 4 = external switch

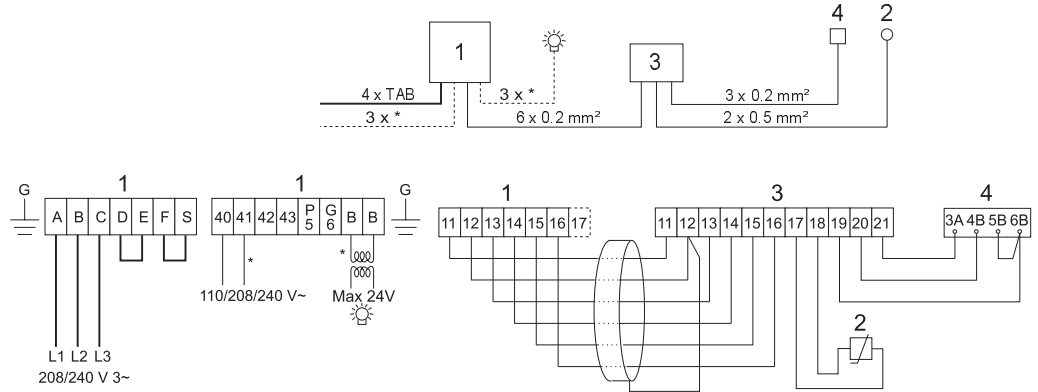

- * AWG 16
- ** Use 60° C copper wire.
- *** Use 75° C copper wire.
- Not UL-listed for more than 48 Amps.

11

STEAM: Type VA, 5 - 13,2 kW, Type VB 6 (5,6 / 7,5 kW) 208 / 240 V~

TAB

kW	208 V~		240 V~	
	Amp	AWG	Amp	AWG
2.5	-	-	11	14
3.8	18	12	-	-
5	24	10*	20	12
5.6	27	8**	-	-
6	30	8**	-	-
6.6	-	-	28	8**
7.5	36	6**	31	8**
9	45	6**	-	-
9.9	-	-	41	6**
10	48	6**	-	-
13.2	-	-	55	6***

- 1 = VA, VB
- 2 = thermistor (sensor)
- 3 = CC10, CC50, CC100
- 4 = external switch

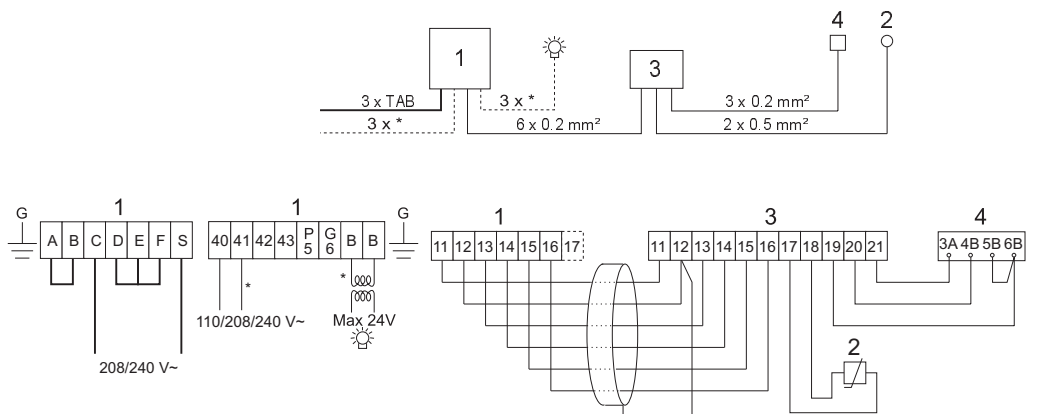

- * AWG 16
- ** Use 60° C copper wire.
- *** Use 75° C copper wire.
- Not UL-listed for more than 48 Amps.

12 STEAM: Type VB 2/4 (2.5 kW) 240 V~

TAB

kW	240 V~ Amp	Awg
2.5	11	14

- 1 = VB
- 2 = thermistor (sensor)
- 3 = CC10, CC50, CC100
- 4 = external switch

* AWG 16
 ** Use 60° C copper wire.
 *** Use 75° C copper wire.
 Not UL-listed for more than 48 Amps.

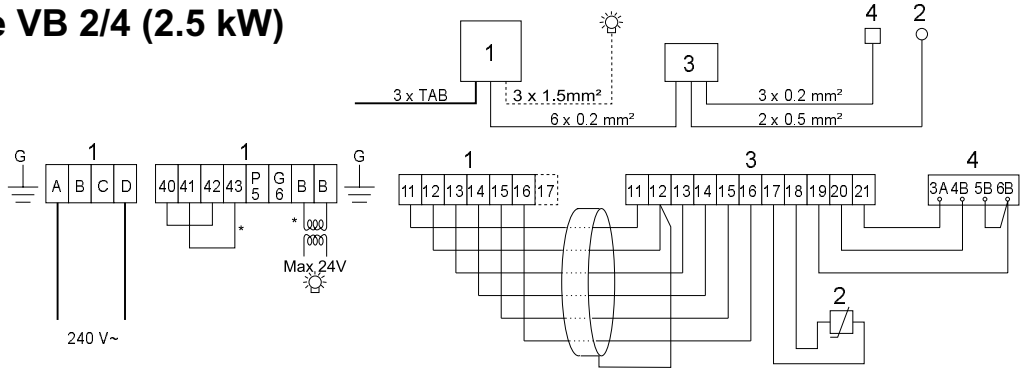

13 STEAM: Type VB 2/4 (2,2 kW) 110 / 120 V~

TAB

kW	110-120 V~ Amp	Awg
2.2	20	12

- 1 = VB
- 2 = thermistor (sensor)
- 3 = CC10, CC50, CC100
- 4 = external switch

* AWG 16
 ** Use 60° C copper wire.
 *** Use 75° C copper wire.
 Not UL-listed for more than 48 Amps.

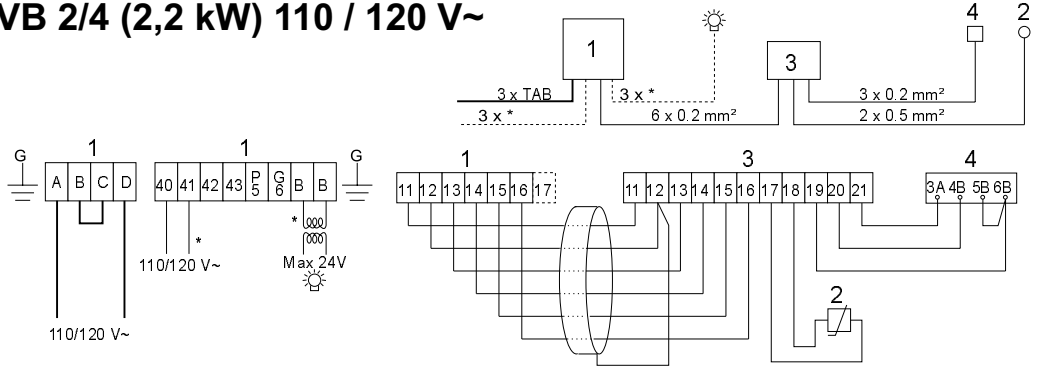

14 STEAM: Type VB 2/4 (3,8 / 5,0 kW) 208 / 240 V~

TAB

kW	208 V~ Amp	Awg	240 V~ Amp	Awg
3.8	18	12	-	-
5	-	-	20	12

- 1 = VB
- 2 = thermistor (sensor)
- 3 = CC10, CC50, CC100
- 4 = external switch

* AWG 16
 ** Use 60° C copper wire.
 *** Use 75° C copper wire.
 Not UL-listed for more than 48 Amps.

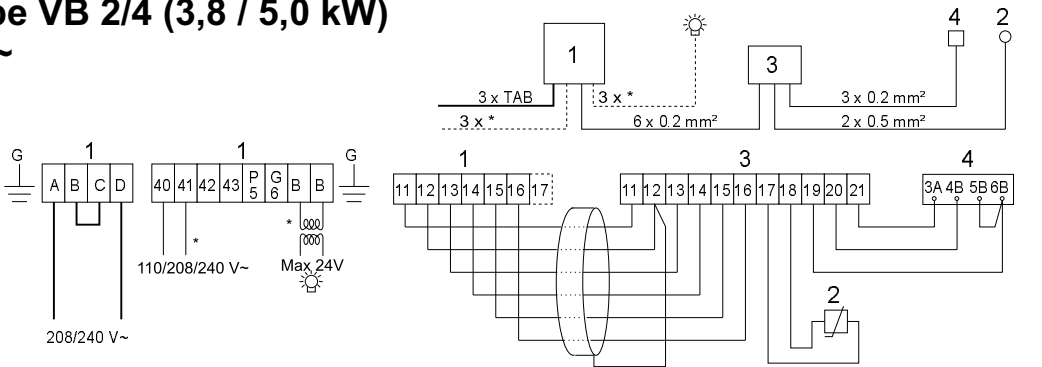

15 STEAM: Type VA (2x), Type VB (2x)

- 1 = VA (2x), VB (2x)
- 2 = thermistor (sensor)
- 3 = CC10, CC50, CC100
- 4 = external switch

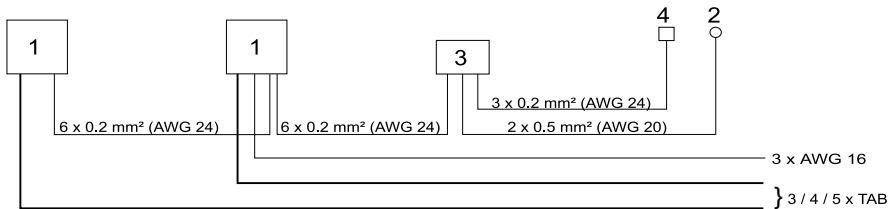

16

DIP-switch	Function	DIP-switch	Function
	1 Hour		6 Hour
	2 Hour		NO TIMER
	4 Hour		TEST

• = Switch position at the DIP-switch.